

(No Model.)

5 Sheets—Sheet 2.

F. SNOW.
CARVING MACHINE.

No. 467,597.

Patented Jan. 26, 1892.

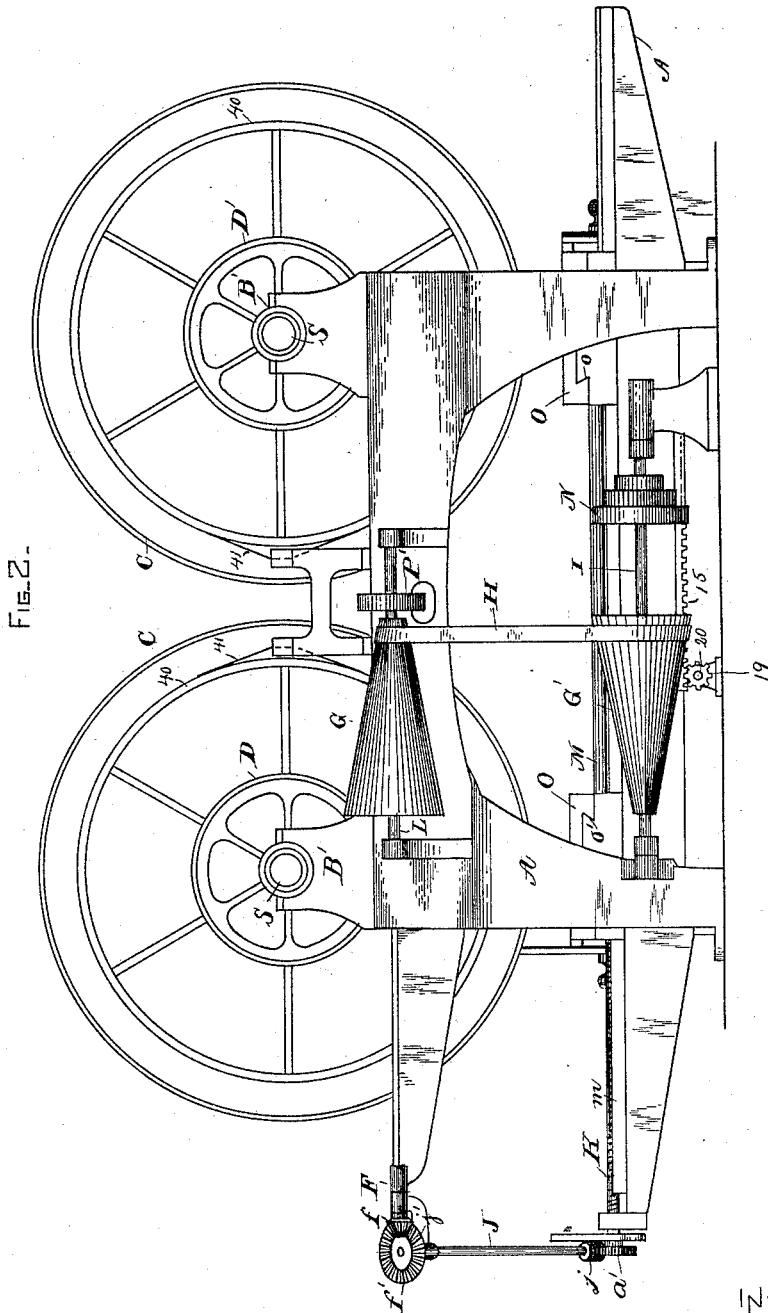

FIG. 2.

WITNESSES.

Alex. F. Macdonald.

Ernestus E. Winkley.

INVENTOR-

Fredrick Snow

By his Attorney

C. A. Phillips

F. SNOW.
CARVING MACHINE.

No. 467,597.

Patented Jan. 26, 1892.

FIG. 3.

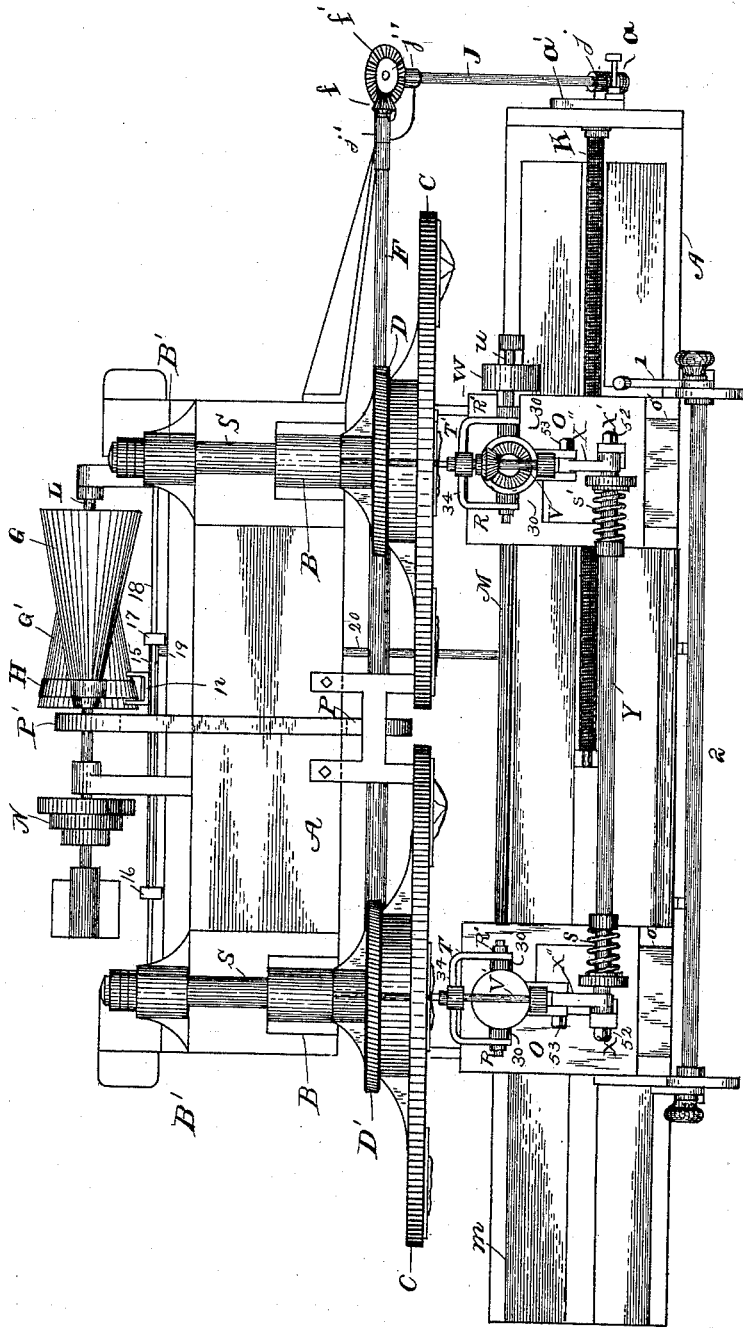

WITNESSES.

Alex. Macdonald.
Erastus E. Winkley.

INVENTOR.

Fredrick Snow
By his Attorneys
E. A. & B. Phillips

(No Model.)

5 Sheets—Sheet 4.

F. SNOW.
CARVING MACHINE.

No. 467,597.

Patented Jan. 26, 1892.

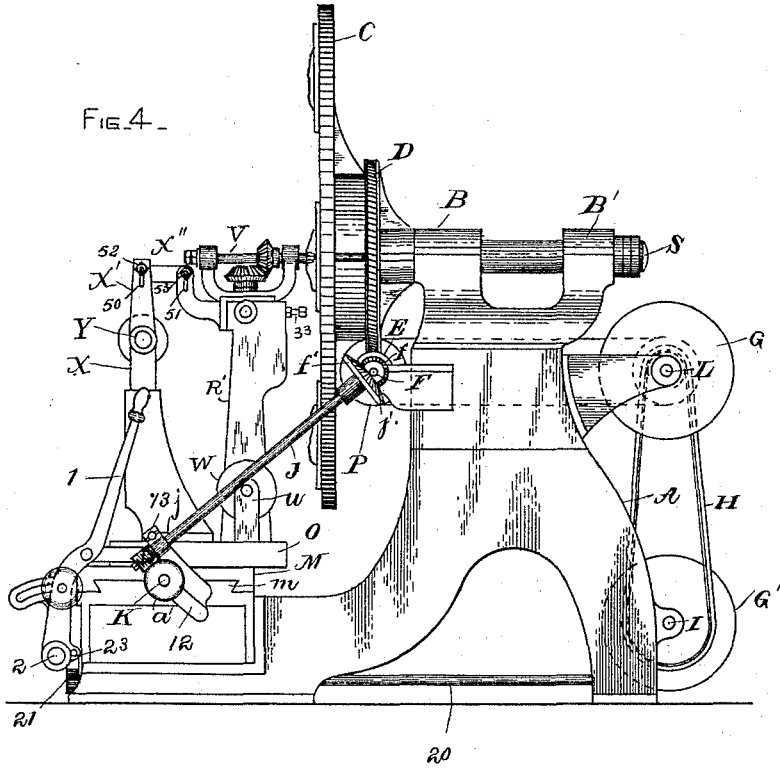
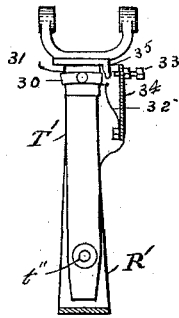

FIG. 7.



WITNESSES.

Alec McDonald.

Erastus E. Winkley.

INVENTOR.

Frederick Snow

By his Attorneys

E. K. & B. Phillips

(No Model.)

5 Sheets—Sheet 5.

F. SNOW.
CARVING MACHINE.

No. 467,597.

Patented Jan. 26, 1892.

FIG. 5.

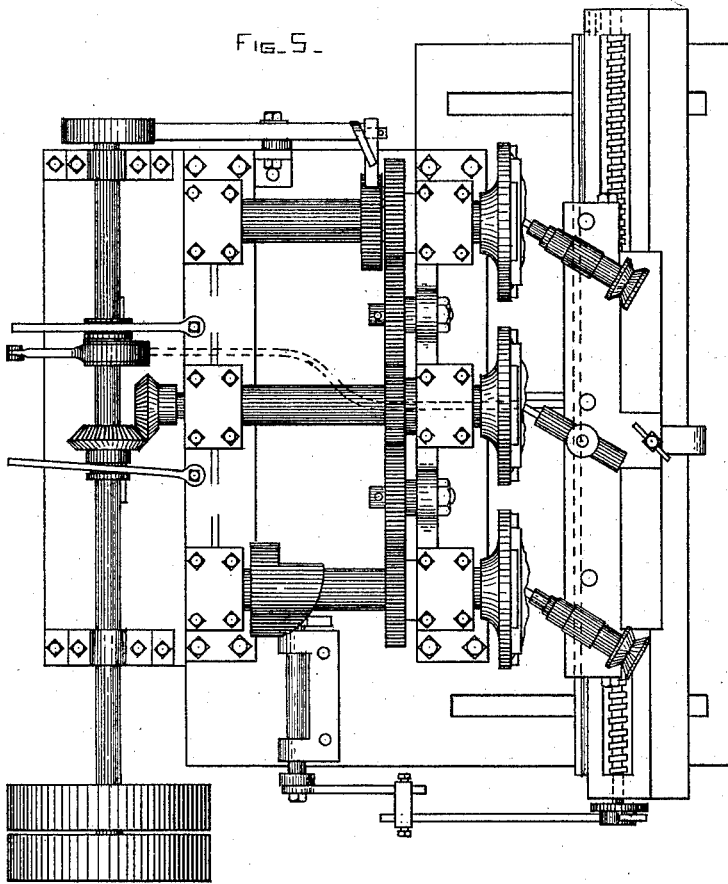
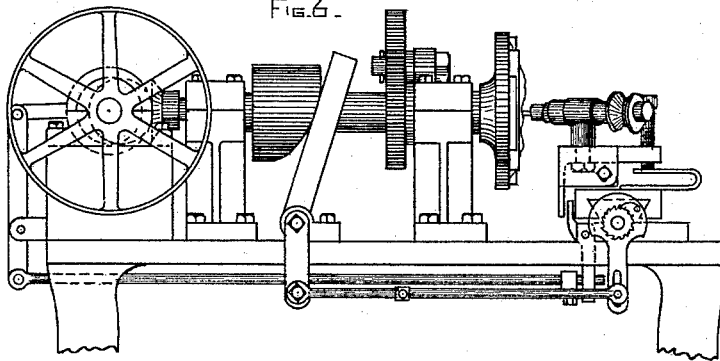

FIG. 6.



WITNESSES—

Alex. McDonald.

Erastus E. Winkley.

INVENTOR—

Fredrick Snow
By his Attorney
E. B. Phillips

UNITED STATES PATENT OFFICE.

FREDERICK SNOW, OF LYNN, MASSACHUSETTS, ASSIGNOR TO THE NATIONAL CARVING COMPANY, OF KITTERY, MAINE.

CARVING-MACHINE.

SPECIFICATION forming part of Letters Patent No. 467,597, dated January 26, 1892.

Application filed August 6, 1891. Serial No. 401,874. (No model.)

To all whom it may concern:

Be it known that I, FREDERICK SNOW, a citizen of the United States, residing at Lynn, in the county of Essex and Commonwealth of Massachusetts, have invented a new and useful Improvement in Carving-Machines, of which the following is a specification.

My invention relates to that class of carving-machines having a tracer and rotating cutting-tools and a series of rotating face-plates; and it consists of improvements in mechanism for rotating and controlling the face-plates and operating and controlling the tracer and rotating cutting-tools.

The object of my invention is to produce a machine of the above class in which, as the tracer and cutting-tools are moved toward the center of the face-plates by the feed, the angular velocity of the face-plates shall be increased, so that the number of linear feet passed over during equal portions of time by the cutters and tracer shall be equal; also, to provide a mechanism for rotating the cutting-tools, the operation of which remains the same for any position thereof; also, to provide a mechanism for imparting a coincident tipping motion to the tool-carriers, the operation of which is not affected by the length of the tipping radius, and which also acts to prevent sagging when the long tipping radius is used, and to further provide other improvements, as hereinafter set forth.

My invention is an improvement upon a machine shown and described in Letters Patent of the United States No. 407,736, dated July 23, 1889, granted to William A. N. Long, for improvements in carving-machines.

My invention is illustrated by the accompanying drawings, in which—

Figure 1 is a front view of a machine embodying my invention. Fig. 2 is a rear view. Fig. 3 is a plan, and Fig. 4 is an end view. Figs. 5 and 6 are respectively a plan and end view, showing so much of the Long machine as will suffice to show the connection of my invention therewith. Fig. 7 is a view showing in detail a part of my invention.

Similar letters and figures refer to similar parts throughout the several views.

The face-plates C C are rigidly mounted on the shafts S S, respectively, which are pro-

vided with suitable bearings B B and B' B' in the frame A.

Secured to the back of the respective face-plates C C are the worm-gears D D', working into the worms E and E' (E' not shown in the drawings) upon the shaft F. The shaft F carries a pulley P, connected by a belt with the pulley P' upon the shaft L.

Upon the shaft L is rigidly mounted a conical pulley G, which is connected by the belt H with the conical pulley G', rigidly mounted upon the shaft I. The shafts F, L, and I are provided with suitable bearings in the frame A. The shaft I carries a pulley N, to which power is applied.

In front of the face-plates C C is a slide-bed M, adapted to move longitudinally along the dovetail *m*, which forms a part of the frame A. The slide-bed M is moved along the dovetail *m* by a mechanism similar to the feed in an ordinary lathe, which consists of a threaded shaft K, which engages with a lug in the under side of the slide-bed, and is provided with bearings in the frame A.

The shaft K is rotated by the following device: Upon one extremity of the shaft F is rigidly mounted a beveled gear *f*, which is in mesh with the beveled gear *f'* upon one extremity of the shaft J. The shaft J is provided with bearings *j* and *j'* upon rigid parts extending from the frame A. Upon the other extremity of the shaft J is a worm *a*, which engages with the worm-gear *a'* upon the shaft K.

Upon the slide-bed M is the tool-carrier frame O, which is free to slide transversely along the dovetails *o* and *o'*. Motion along the dovetails *o* and *o'* may be imparted to the tool-carrier frame O by means of a lever 1, attached to a shaft 2, which is connected with both ends of the tool-carrier frame by a link-and-lever connection.

Between the standards R R and R' R', which form a part of the tool-carrier frame O, are secured the tool-carriers T and T', free to tip on bearings T T and T' T' in the standards R R and R' R'. Through the bearing T'' runs a shaft *u*, to which is attached a friction-cone 4, which works against a similar friction-cone 5 upon the shaft 6, adapted to rotate in suitable bearings in the tool-carrier

T'. Outside of the tool-carrier T' the shaft *u* carries a pulley W, to which power is applied. Upon the upper end of the shaft 6 is a friction-cone 7, working against a similar friction-cone 8 upon the spindle V. The spindles V and V' are respectively provided with a device for adjusting therein a cutting-tool and tracer. The heads of the tool-carriers T and T' are capable of rotation in a horizontal plane, so that the inclination of the spindles to the faces of the face-plates may be altered. It will be noticed that the axis of the shaft *u* is coincident with the axis of the tool-carrier T' and that the axis of the shaft 6 is coincident with the axis of the head of the tool-carrier T, as above described. The head may be by this arrangement set in any desired position, and the tool-carrier is free to tip forward or back without interfering with the operation of the friction-cones.

To the standards R R and R' R' are attached arcs 30 30 and 31 31, adjustable by means of lugs passing through the standards R R and R' R' and which bear against the tool-carriers T and T' just below the tool-carrier heads, bracing the tool-carriers laterally and preventing side motion thereof when the machine is in operation. Each pair of standards R R' and R R' is connected by a plate 34 34.

Running through a nut in each of the plates 34 and 34 is a bolt 33 33, adapted to strike against a shoulder 35 35 upon each of the tool-carriers T and T', thus preventing the tool and tracer from striking against the face-plates when, in the operation of the machine, they happen to run off of the pattern or material. A spring 32 32 is also secured to each of the plates 34 34, which is adapted to bear against the tool-carriers T and T' before the shoulders 35 35 come in contact with the bolt 33 33, thus preventing a shock to the machine when such contact occurs.

A tilting motion is given to the tool-carriers T and T' by the following device: Supported by the standards X X, which form a part of the tool-carrier frame O, is a rod Y, free to rotate in bearings in said standards. The springs *s* and *s'* are wound around the rod Y and connected therewith and with the standards X X, the tendency of the springs *s* and *s'* being to rotate the rod Y in the direction of the face-plates C C. The rod Y is connected with the tool-carriers T and T' by the connecting-levers X' X' and X'' X'', and the effort exerted by the springs *s* and *s'* is thus exerted upon the upper portion of the tool-carriers T and T' above the tipping axis and acts to keep the tracer and cutting-tools in contact with the work. The belt H runs through a fork *n*, which is attached to a rack 15, supported by the lugs 16 and 17 from a rod 18, which forms a part of the frame A and is free to slide thereon. Working in the rack 15 is a pinion 19, attached to a shaft 20, provided with suitable bearings upon the frame A, and the opposite extremity of which is at-

tached to a pinion 21, working in a rack 22, rigidly secured to a rod 23, which is mounted upon the slide-bed M. The face-plates C C are provided with the flanges 40 40, around which run the belts 41 41, friction between the flanges 40 40 and belts 41 41, during the rotation of the face-plates, acting to prevent sudden increase in the velocity thereof when the tracer and cutting-tools run off the work.

The operation of my invention is as follows: Power being applied to rotate pulley N, rotary motion is communicated to the conical pulley G', and thence by the belt H to the conical pulley G, and thence by the pulley P' and connecting-belt to the pulley P on the worm-shaft F, and thence by means of the worms E E' and the worm-gears D and D' to the face-plates C C, and at the same time, by the extension of the shaft F and connecting-shaft J and a connecting system of gearing, rotary motion is imparted to the threaded shaft K and slide-bed M, fed along the dovetail *m*, carrying the tool-carrier frame O, thereby moving the tracer and cutting-tools along the face-plates and carrying the rack 22 over the pinion 21, thereby producing a rotation of the shaft 20, an attached pinion 19 sliding the rack 15 along the shaft 18, and by means of the fork *n* pushing the belt H along the conical pulleys G and G', thus increasing or diminishing the angular velocity of the face-plates. If the feed is from the outside of the machine toward the center, the angular velocity of the face-plates is increased, and the reverse is the result when the feed is reversed. The rate at which such increase or decrease occurs is dependent upon the inclination of the conical pulleys G and G'. Power is also applied to the pulley W by means of a belt from any convenient source, imparting a rotary motion to the shaft *u*, which is communicated by means of the friction-cones 4 5 to the shaft 6 and by means of the friction-cones 7 8 to the spindle V. As the face-plates C C are rotated, the tracer being carried over the surface of the pattern, against which it is held, as hereinbefore described, by the action of the springs *s* and *s'*, a tipping motion is imparted to the tool-carrier T, which, by means of the levers X' X'', imparts a rotary motion to the rod Y, which, by means of the levers X' and X'', produces coincident tipping motion of the tool-carrier T' and the cutting-tools.

It is evident that in carving-machines of this class a tool-carrier with a long tipping radius, by allowing the motion of the tools toward or away from the face-plates to occur practically in the plane perpendicular thereto, if quickness of action can be secured and sagging of parts prevented, will greatly increase the accuracy of the reproduction of objects by the machine, especially in the case of objects of large size with marked elevations and depressions, as it prevents the machine from jumping depressions and enables it to follow accurately down the side of ele-

10 vations. By connecting the levers X' X' with each of the tool-carriers above its tipping axis I secure a quick motion for any length of tipping axis, and by the arrangement of the levers X' and X' and X' and X' and the rod Y, I prevent the sagging of parts, for it is evident that the slightest motion toward or away from the face-plates of either of the tool-carriers will produce a rotation of the rod Y and a corresponding motion toward or away from the face-plates of all other tool-carriers.

15 As shown in Fig. 4, the levers X' X' are adjustable in the slots 50 50 and 51 51 by means of set-screws 52 52 and 53 53. By means of this adjustment the extent of the tipping motion given to the tool-carriers by a given rotation of the rod Y may be varied. By different adjustments of the respective levers X' X' the cutting-tool may be made to cut an object, the depressions and elevations in which are more marked than on the pattern, or the opposite result may be produced.

25 The minor devices shown in the drawings and which form a part of my invention have already been sufficiently described.

I claim as my invention, and desire to secure by Letters Patent, in a carving-machine—

30 1. The combination of a series of rotating face-plates, a series of tool-carriers adapted to receive a tipping motion and carrying, respectively, a tracer and rotating cutting-tool, and a rotating shaft, the axis of which is coincident with the tipping axis of the tool-carriers, and which is connected by connecting-shafts and a system of connecting friction-cones with the respective cutting-tools, all substantially as set forth, and for the purposes specified.

45 2. A device for imparting rotary motion to the cutting-tools, consisting of a shaft to which power is applied, the axis of which is coincident with the tipping axis of the tool-carrier, a shaft provided with suitable bearings in the tool-carrier, and the axis of which is coincident with the axis about which the tool-carrier head is adjustable, and friction-cones connecting said shafts with each other and with the spindle carrying the cutting-tool, all substantially as set forth, and for the purposes specified.

55 3. The combination of a series of rotating face-plates, a series of tool-carriers adapted to carry a tracer and rotating cutting-tools, and mechanism for imparting a tipping motion to said tool-carriers in the direction of the face-plates, connected with each tool-carrier at a point above its tipping axis, all substantially as set forth, and for the purposes specified.

65 4. The combination of a series of rotating face-plates, a tool-carrier frame upon which are mounted a series of tool-carriers adapted to receive a tipping motion and carrying, re-

spectively, a tracer and rotating cutting-tools, a revoluble rod mounted in bearings in said tool-carrier frame, a spring acting to rotate said rod in the direction of said face-plates, and levers connecting said rod with each of said tool-carriers at a point above its tipping axis, all substantially as set forth, and for the purposes specified.

75 5. A device for rendering the tipping motion of the tool-carriers coincident, consisting of a revoluble rod mounted in suitable bearings and connected by levers with each of the tool-carriers at a point above its tipping axis, all substantially as set forth, and for the purposes specified.

80 6. A device for preventing lateral vibration of the tool-carriers, consisting of uprights secured to the tool-carrier frame, provided with parts adapted to bear against each side of the carrier and between which the tool-carrier slides when a tipping motion is imparted thereto, all substantially as set forth, and for the purposes specified.

85 7. A device for preventing the tracer and cutting-tools from coming in contact with the face-plates, consisting of a device supported by uprights between the tool-carriers and face-plates and adapted to come in contact with the tool-carrier before the tracer or cutting-tool comes in contact with the face-plates, all substantially as set forth, and for the purposes specified.

90 8. The combination of the following instrumentalities, to wit: a series of rotating face-plates, a series of tool-carriers carrying, respectively, a tracer and rotating cutting-tools, a device for feeding the same across the faces of the face-plates, a device for increasing the angular velocity of the face-plates as the same are fed in toward the center, and a device for communicating a rotary motion along the tipping axis of the tool-carrier by connecting mechanism to the cutting-tools, all substantially as set forth, and for the purposes specified.

95 9. The combination of the following instrumentalities, to wit: a series of rotating face-plates, a series of tool-carriers adapted to receive a tipping motion and carrying, respectively, a tracer and rotating cutting-tools, a device for feeding the same across the faces of the face-plates, a device for increasing the angular velocity of the face-plates as the same are fed in toward the center, and mechanism for imparting a tipping motion to the tool-carriers, connected with each above its tipping axis, all substantially as set forth, and for the purposes specified.

100 10. The combination of the following instrumentalities, to wit: a series of rotating face-plates, a series of tool-carriers adapted to receive a tipping motion, a device for communicating rotary motion along the tipping axis of the tool-carriers by connecting mechanism to the cutting-tools, and a device for imparting a tipping motion to the tool-carriers, connected

with each at the point above its tipping axis, all substantially as set forth, and for the purposes specified.

11. A device for imparting rotary motion to the cutting-tools, consisting of a rotating shaft, the axis of which is coincident with the tipping axis of the tool-carrier, and a connecting-shaft mounted in bearings in the tool-carrier and communicating the rotary motion of said shaft by means of connecting friction-cones to the cutting-tools, all substantially as set forth, and for the purposes specified.

12. The combination of the following instrumentalities, to wit: a series of rotating face-plates, a series of tool-carriers adapted to receive a tipping motion and carrying, respectively, a tracer and rotating cutting-tools, a device for feeding the same across the faces of the face-plates, a device for increasing the angular velocity of the face-plates as the same are fed in toward the center, a device for communicating rotary motion along the tipping axis of the tool-carrier by connecting mechanism to the cutting-tools, mechanism for imparting a tipping motion to the tool-carriers, connected with each above its tipping axis, a device for preventing a sudden increase in the angular velocity of the face-plates, and a device for preventing the tracer and cutting-tools from coming in contact with the face-plates, all substantially as set forth, and for the purposes specified.

13. A device for preventing a sudden in-

crease in the angular velocity of the face-plates, consisting of the flanges 40 40, connected with the respective face-plates and turning therewith in the stationary band 41 41, secured to some permanent part of the apparatus, all substantially as set forth, and for the purposes specified.

14. A device for regulating the action of the cutting-tools, consisting of a revoluble rod mounted in bearings in the tool-carrier frame and connected with each of the tool-carriers above its tipping axis by adjustable connecting-levers, all substantially as set forth, and for the purposes specified.

15. A device for varying the angular velocity of the face-plates, consisting of the conical pulleys G and G' and the belt H, connecting the mechanism for rotating the face-plates with the shaft to which power is applied, a rack 22, adapted to be carried by the feed over the pinion 21, a shaft 20, connecting the pinion 21 with the pinion 19, and a rack 15, adapted to receive longitudinal motion from the pinion 19, and carrying the fork n, between the prongs of which the belt H runs, all substantially as set forth, and for the purposes specified.

Dated at Lynn, this 4th day of August, A. D. 1891.

FREDERICK SNOW.

In presence of—
LILA L. HILL,
BENJAMIN PHILLIPS.